

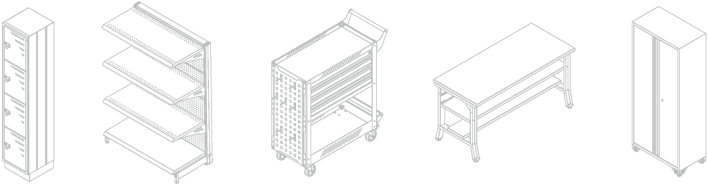

STORE YOUR FUTURE

Master Catalog



2026

STORE YOUR
FUTURE



At **Starkguard**, we combine Mexican engineering, technological innovation and world-class standards to deliver products that maximize efficiency, safety and performance.

“Robust solutions. Long lasting results.”

CABINETS

04

RACKS

28

LOCKERS

36

WORKSHOP FURNITURE

40

SAFES

49

RETAIL SHELVING

52

A red cabinet is positioned on the right side of the image. The background is a blurred warehouse or industrial setting with white walls, a grey floor, and overhead fluorescent lights. In the distance, there are some yellow and blue equipment or structures.

Total protection for your
tools and assets.

CABINET

STORE YOUR
FUTURE



TALL CABINET

INNOVATION LINE

STORE YOUR
FUTURE

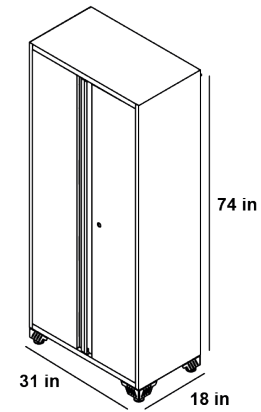

Available colors



Load capacity
per level



Total load
capacity

Key features

- Lockable doors.
- Soft-close hinges.
- Includes 4 adjustable-height shelves.
- Electrostatic powder coating.

Recommended uses

Garages, detailing studios, workshops, warehouses, industry, offices, schools, and laboratories.

BASE CABINET WITH DRAWERS

INNOVATION LINE

STORE YOUR
FUTURE

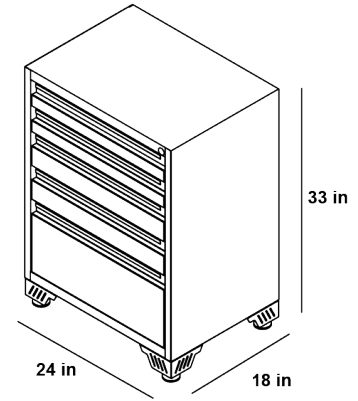

Available colors



Load capacity
per drawer



Total load
capacity

Key features

- Greater stability.
- Electrostatic powder coating.

Recommended uses

Garages, detailing studios, workshops, warehouses, industry, offices, schools, and laboratories.

BASE CABINET WITH DOORS

INNOVATION LINE

STORE YOUR
FUTURE

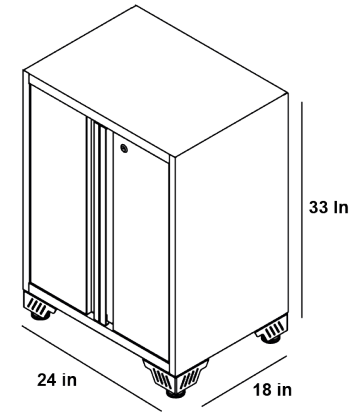

Available colors



Load capacity
per level



Total load
capacity

Key features

- Includes shelf.
- Soft-close hinges.
- Electrostatic powder coating.
- Lockable doors.

Recommended uses

Garages, detailing studios, workshops, warehouses, industry, offices, schools, and laboratories.

WALL CABINET

INNOVATION LINE

STORE YOUR
FUTURE

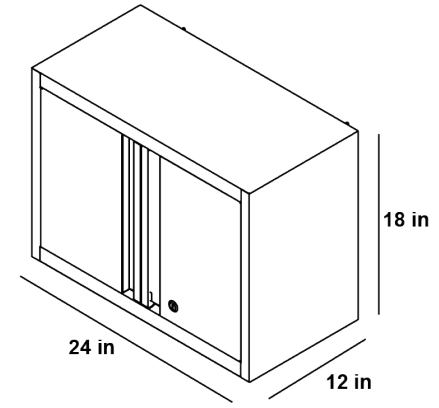

Available colors



Total load capacity

Key features

- Lockable doors.
- Soft-close hinges.
- Electrostatic powder coating.
- Perforated back panel for wall mounting.

Recommended uses

Garages, detailing studios, workshops, warehouses, industry, offices, schools, and laboratories.

STORE YOUR
FUTURE

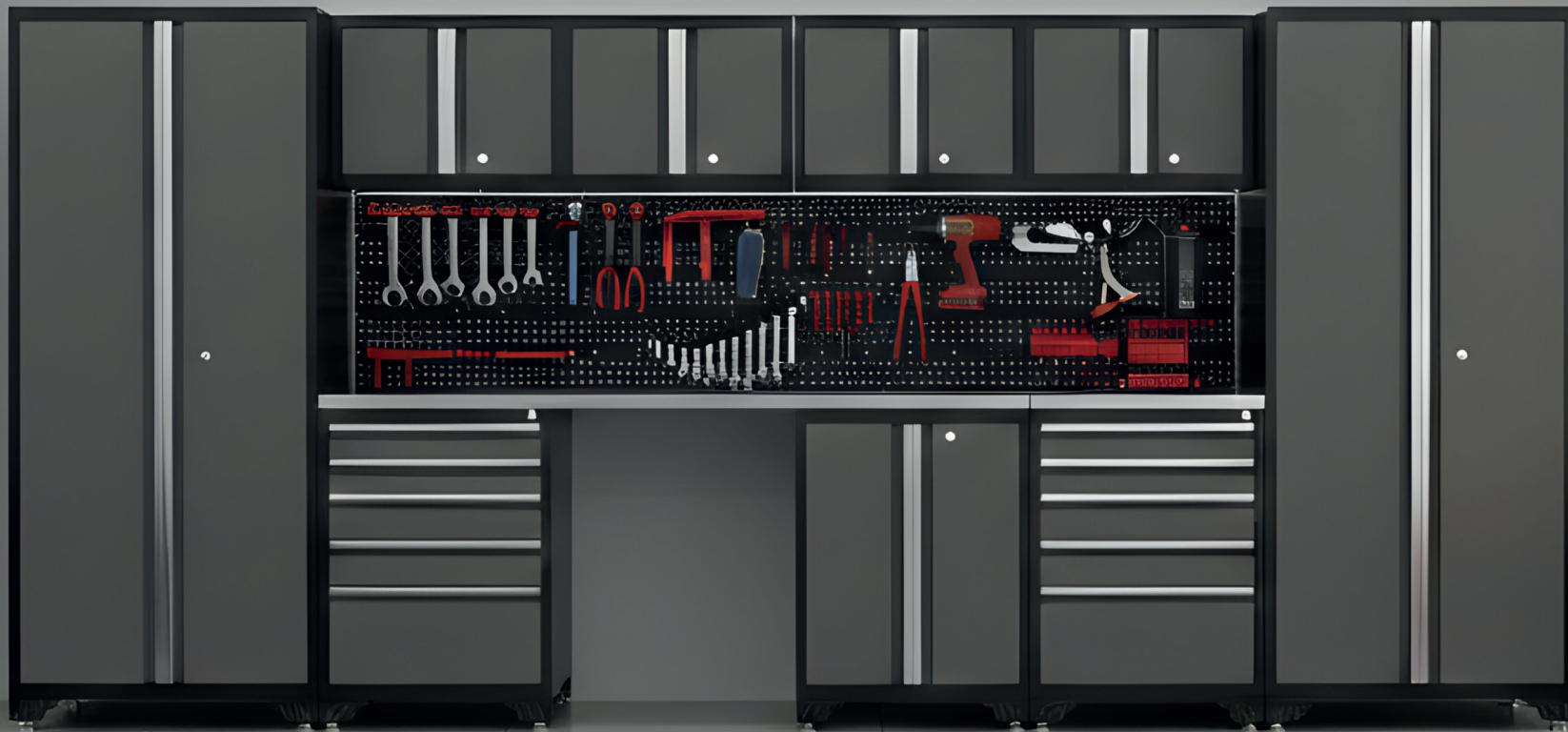

*Recommended applications

SLATWALL

INNOVATION LINE (ACCESSORIES)

STORE YOUR
FUTURE

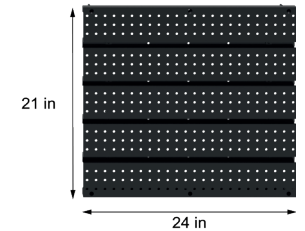
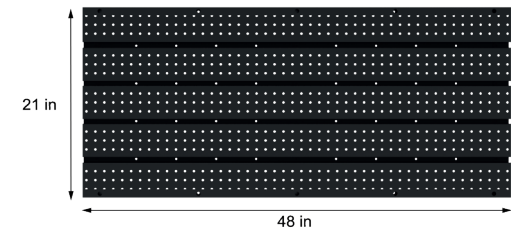
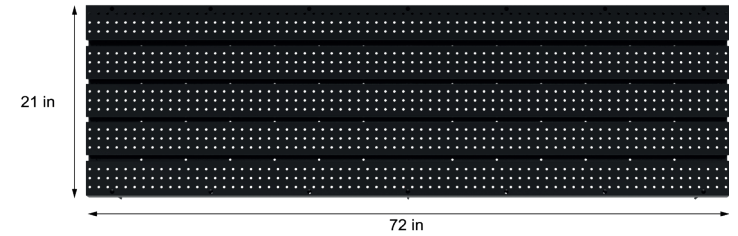
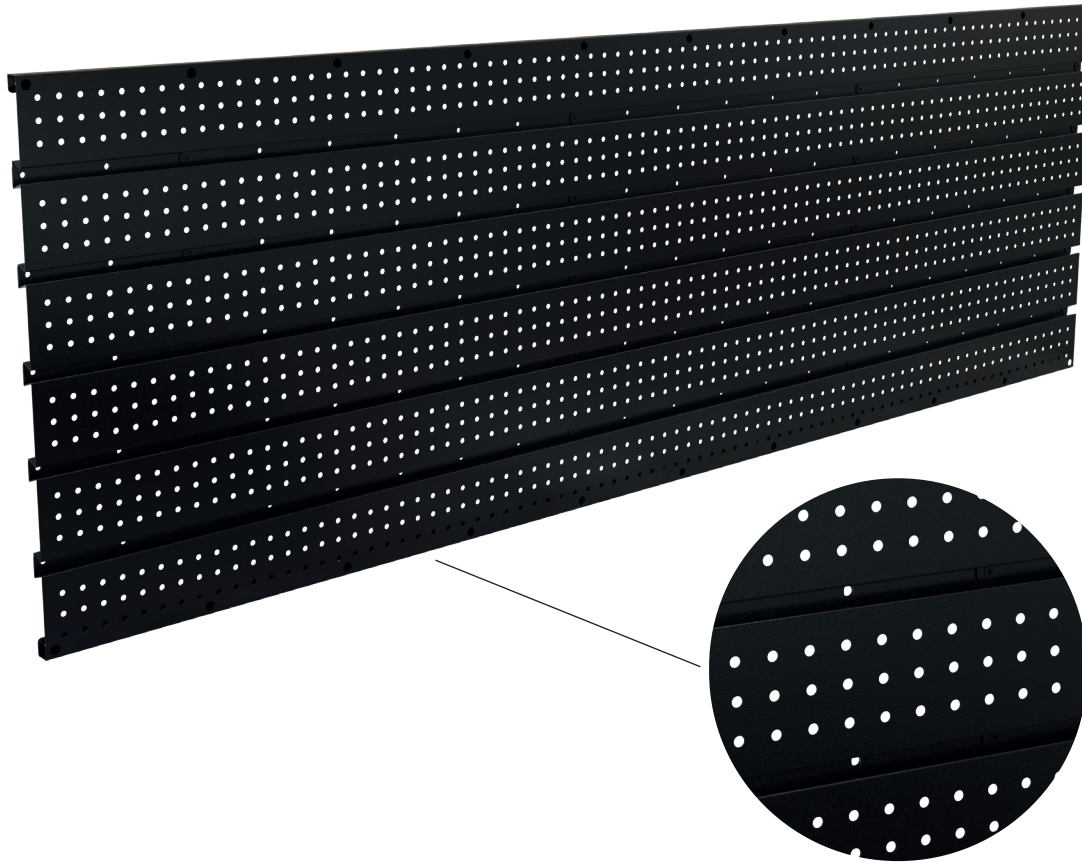

Key features

- 18-gauge steel structure.
- Compatible with hooks and organizing accessories.
- Designed for the “Innovation” line.
- Electrostatic powder coating.

Available colors



Recommended uses

Garages, detailing studios, workshops, storage, industry, offices, schools, and laboratories.

COUNTERTOP

INNOVATION LINE (ACCESSORIES)

STORE YOUR
FUTURE

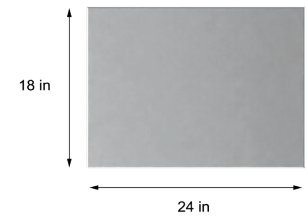
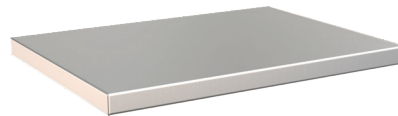
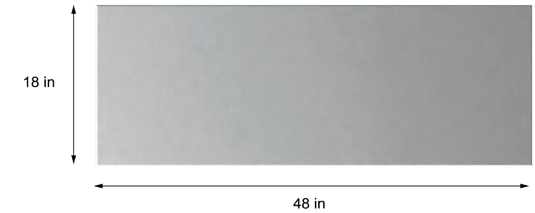
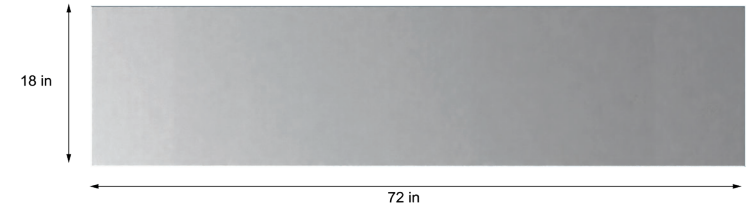

Key features

- Made of 18-gauge stainless steel.
- 1.3 in thickness.
- Designed for the “Innovation” line.

Available colors



Recommended uses

Garages, detailing studios, workshops, storage, industry, offices, schools, and laboratories.

STORE YOUR
FUTURE



TALL CABINET

MASTER LINE

STORE YOUR
FUTURE

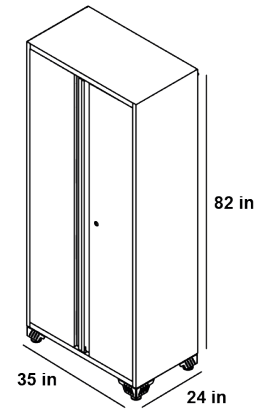

Available colors



Load capacity
per level



Total load
capacity

Key features

- 18-gauge steel structure.
- Lockable doors.
- Electrostatic powder coating.
- Includes 4 adjustable-height shelves.

Recommended uses

Garages, detailing studios, workshops, warehouses, industry, offices, schools, and laboratories.

BASE CABINET WITH DRAWERS

MASTER LINE

STORE YOUR
FUTURE

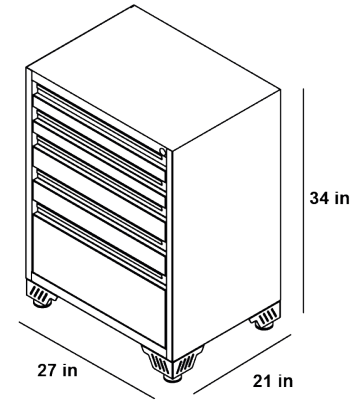

Available colors



Load capacity
per drawer



Total load
capacity

Key features

- Greater stability.
- Electrostatic powder coating.
- 18-gauge steel structure.

Recommended uses

Garages, detailing studios, workshops, warehouses, industry, offices, schools, and laboratories.

BASE CABINET WITH DOORS

MASTER LINE

STORE YOUR
FUTURE

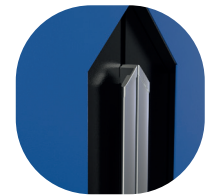
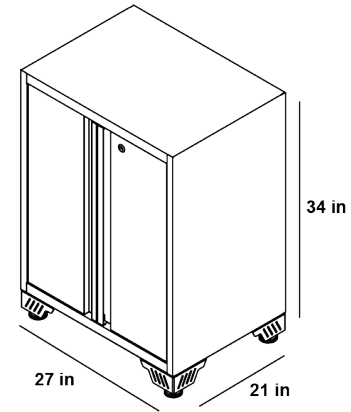

Available colors



Load capacity
per level



Total load
capacity

Key features

- 18-gauge steel structure.
- Includes shelf.
- Soft-close hinges.
- Electrostatic powder coating.

Recommended uses

Garages, detailing studios, workshops, warehouses, industry, offices, schools, and laboratories.

WALL CABINET

MASTER LINE

STORE YOUR
FUTURE

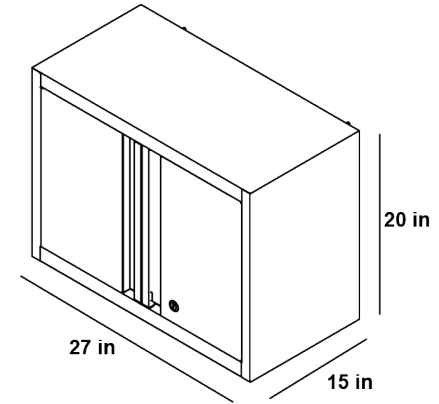

Available colors



Load capacity
per level



Total load
capacity

Key features

- 18-gauge steel structure.
- It includes one shelf.
- Soft-close hinges.
- Perforated panel for wall mounting.
- Electrostatic powder coating.

Recommended uses

Garages, detailing studios, workshops, warehouses, industry, offices, schools, and laboratories.

SLATWALL

MASTER LINE (ACCESSORIES)

STORE YOUR
FUTURE

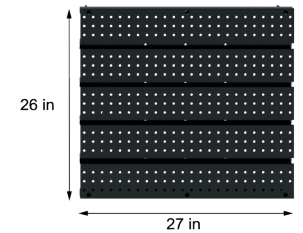
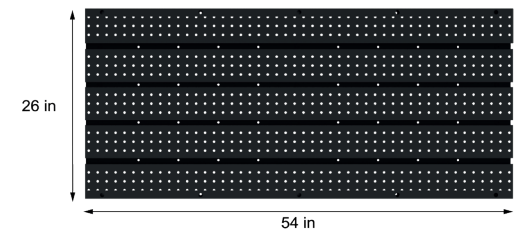
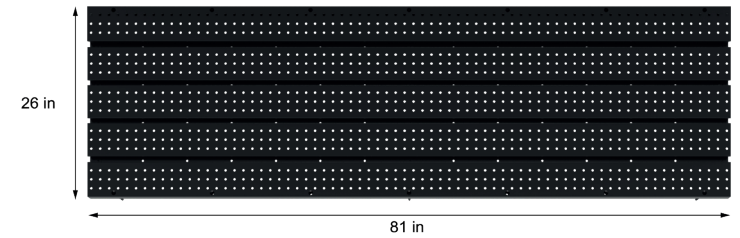
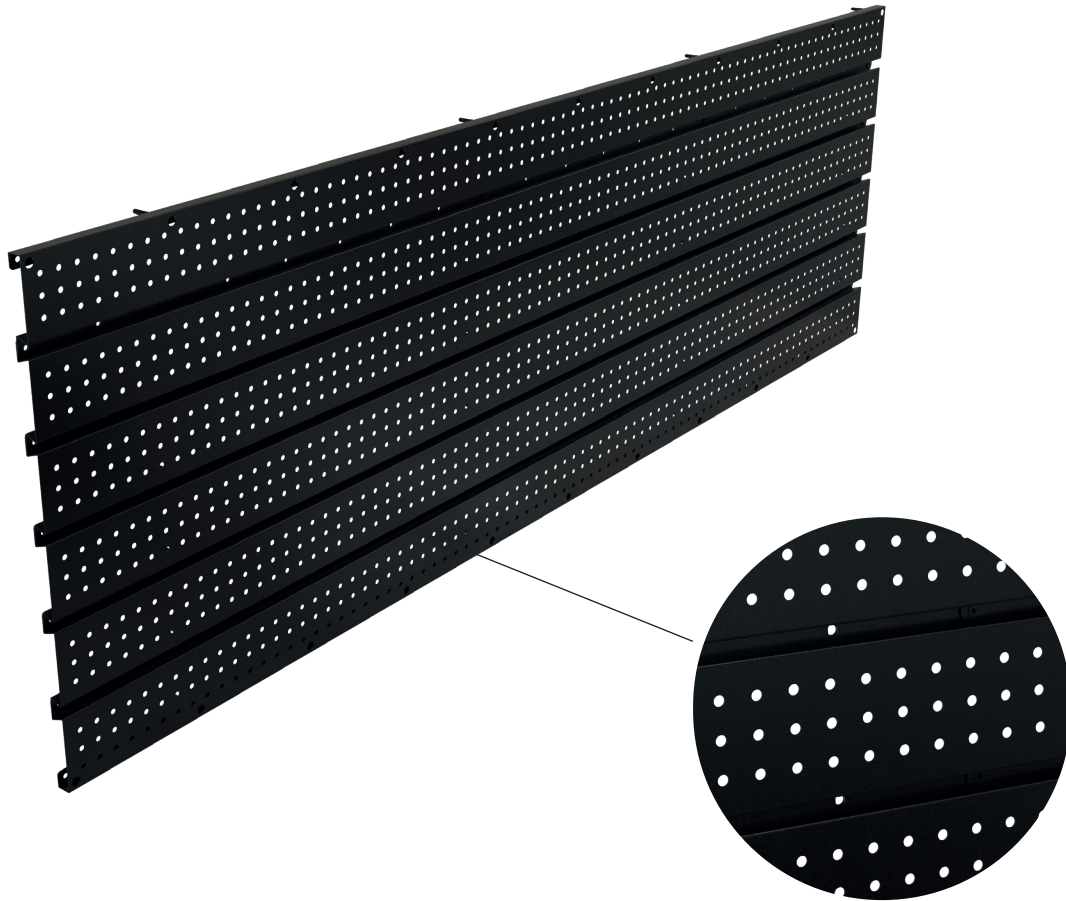

Key features

- 18-gauge steel structure.
- Compatible with hooks and organizing accessories.
- Designed for the “Master” line.
- Electrostatic powder coating.

Available colors



Recommended uses

Garages, detailing studios, workshops, storage, industry, offices, schools, and laboratories.

COUNTERTOP

MASTER LINE (ACCESSORIES)

STORE YOUR
FUTURE

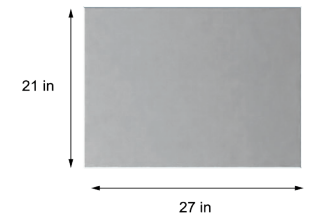
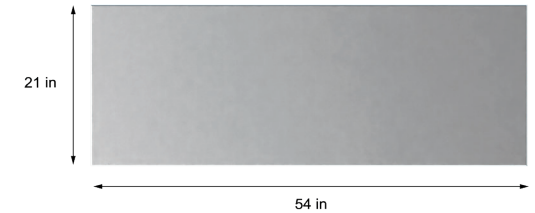
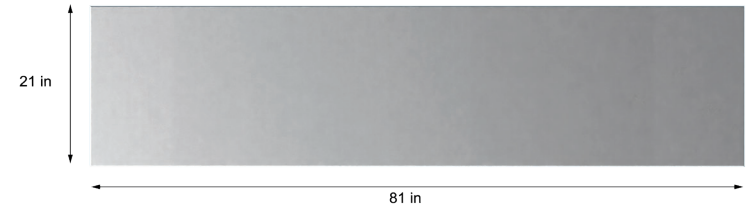

Key features

- Made of 18-gauge stainless steel.
- 1.3 in thickness.
- Designed for the “Master” line.

Available colors



Recommended uses

Garages, detailing studios, workshops, storage, industry, offices, schools, and laboratories.

STORE YOUR
FUTURE



TALL CABINET

NOVA LINE

STORE YOUR
FUTURE

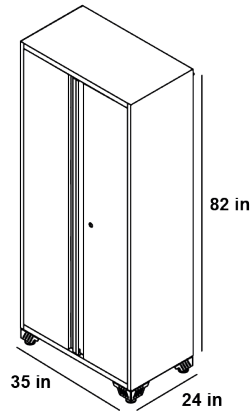

Key features

- 20-gauge steel structure.
- Doors with security lock.
- Soft-close hinges.
- Includes 4 adjustable-height shelves.
- Electrostatic powder coating.

Recommended uses

Garages, detailing studios, workshops, warehouses, industry, offices, schools, and laboratories.



Available colors



Load capacity
per level



Total load
capacity

BASE CABINET WITH DRAWERS

NOVA LINE

STORE YOUR
FUTURE

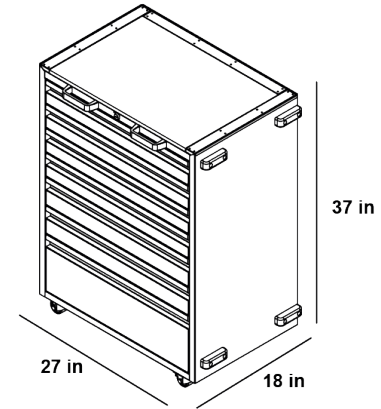

Available colors



Load capacity
per drawer



Total load
capacity

Key features

- 20-gauge steel structure.
- 4 industrial-grade swivel casters.
- 2 locking casters.
- Smooth-glide drawers.
- Heavy-duty ergonomic handles.
- Electrostatic powder coating.

Recommended uses

Garages, detailing studios, workshops, warehouses, industry, offices, schools, and laboratories.

BASE CABINET WITH DOORS

NOVA LINE

STORE YOUR
FUTURE

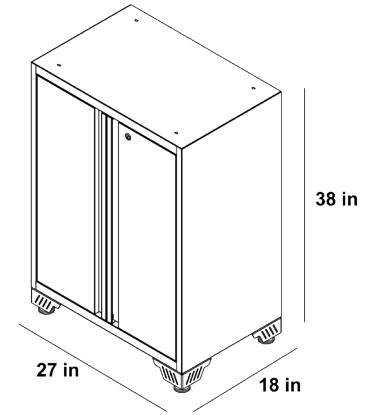

Available colors



Load capacity
per level



Total load
capacity

Key features

- 20-gauge steel structure.
- Double swing doors.
- Internal metal shelf.
- Secure front locking system.

Recommended uses

Garages, detailing studios, workshops, warehouses, industry, offices, schools, and laboratories.

LARGE WALL CABINET

NOVA LINE

STORE YOUR
FUTURE

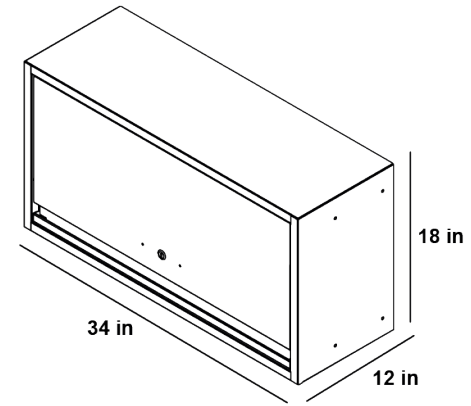

Available colors



Total load capacity

Key features

- 20-gauge steel structure.
- Assisted vertical opening system.
- Dual gas struts.
- Integrated lighting.

Recommended uses

Garages, detailing studios, workshops, warehouses, industry, offices, schools, and laboratories.

SMALL WALL CABINET

NOVA LINE

STORE YOUR
FUTURE

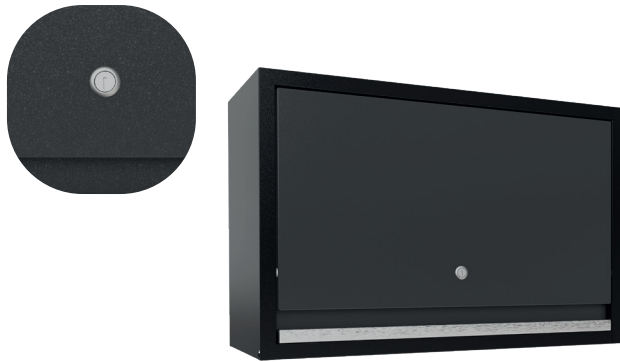
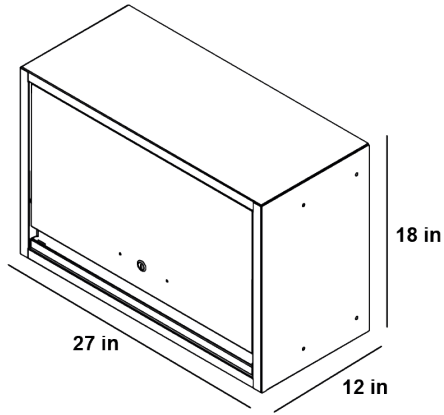

Key features

- 20-gauge steel structure.
- Assisted vertical opening system.
- Dual gas struts.
- Integrated lighting.

Recommended uses

Garages, detailing studios, workshops, warehouses, industry, offices, schools, and laboratories.



Available colors



Total load capacity

SLATWALL

NOVA LINE (ACCESSORIES)

STORE YOUR
FUTURE

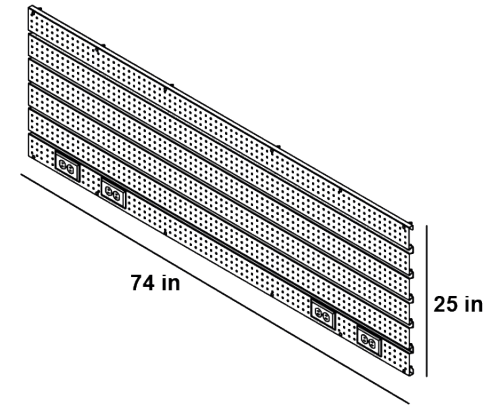
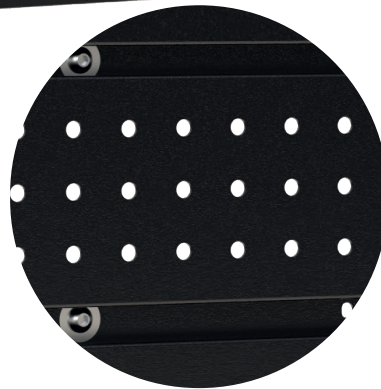
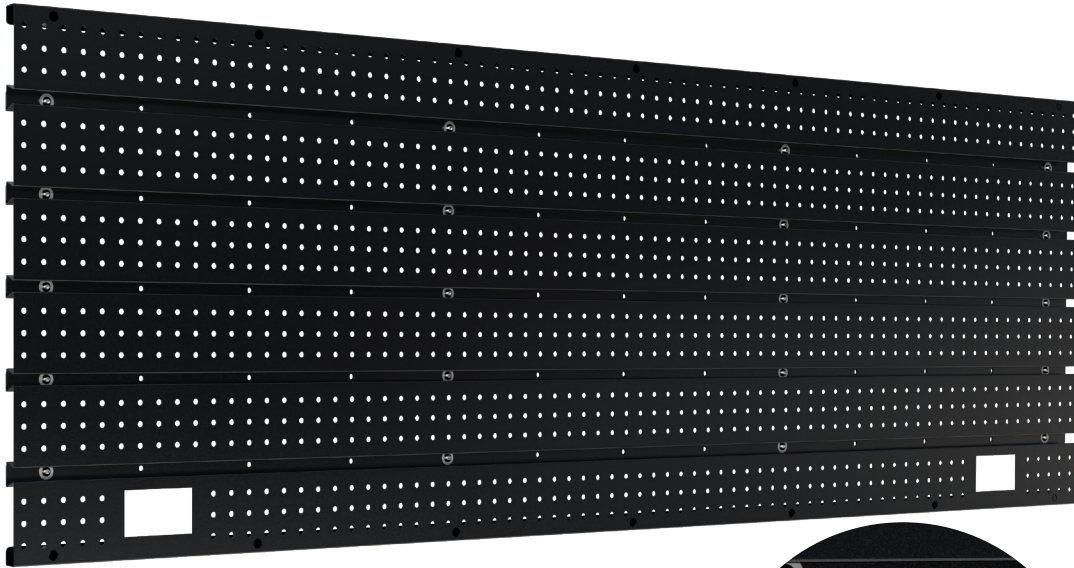

Key features

- 18-gauge steel structure.
- Designed for the “Nova” line.
- High-rigidity perforated pegboard.
- Built-in slots for electrical outlets.
- Compatible with hooks and organizing accessories.
- Electrostatic powder coating.

Available colors



Recommended uses

Garages, detailing studios, workshops, storage, industry, offices, schools, and laboratories.

COUNTERTOP

NOVA LINE (ACCESSORIES)

STORE YOUR
FUTURE

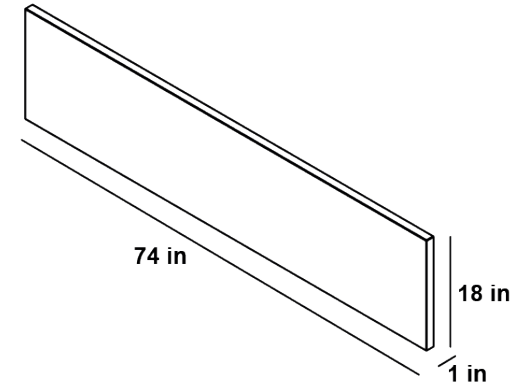
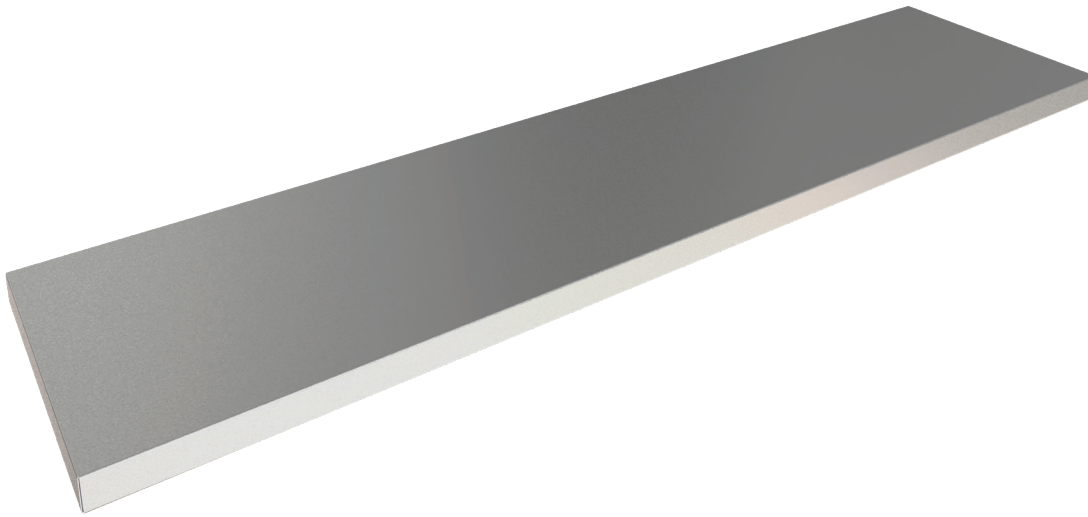

Key features

- Made of 18-gauge stainless steel.
- 1.3 in thickness.
- Designed for the “Nova” line.
- Impact-resistant and heavy-duty.

Available colors



Recommended uses

Garages, detailing studios, workshops, storage, industry, offices, schools, and laboratories.

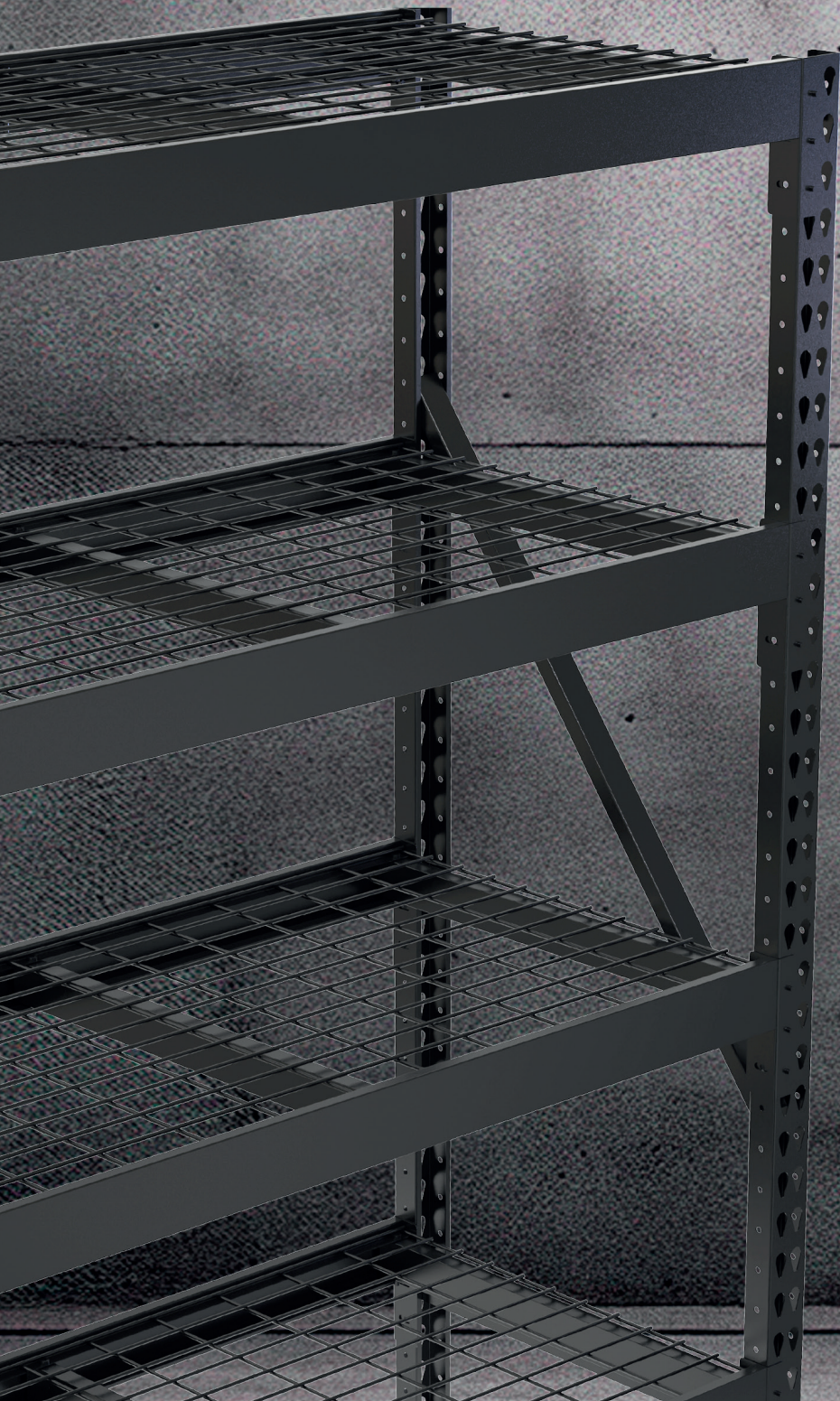

Maximize
the profitability of each
meter in your warehouse.

RACKS

4 SHELF STORAGE RACK

STORE YOUR
FUTURE

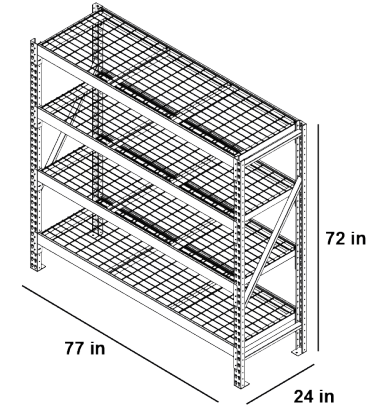

Available colors



Load capacity
per level



Total load
capacity

Key features

- 18-gauge steel structure.
- Adjustable height per level.
- Sturdy yet lightweight design.
- Easy assembly.
- Electrostatic powder coating.

Recommended uses

Workshops, warehouses, factories, offices, educational centers, and exhibitions.

3-LEVEL MODULAR RACK

STORE YOUR
FUTURE

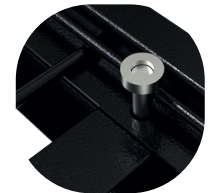
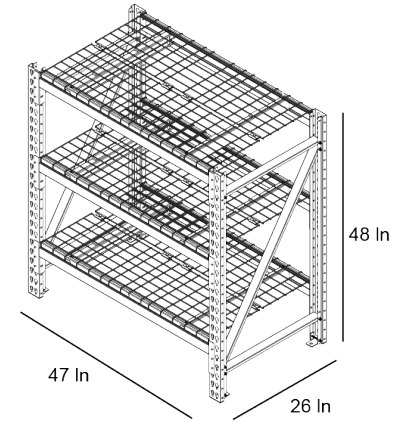

Available colors



Load capacity
per level



Total load
capacity

Key features

- 18-gauge steel structure.
- Adjustable height per level.
- Sturdy yet lightweight design.
- Easy assembly.
- Electrostatic powder coating.

Recommended uses

Workshops, warehouses, factories, offices, educational centers, and exhibitions.

4-LEVEL STANDARD MODULAR RACK

STORE YOUR
FUTURE

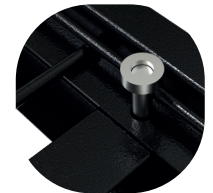
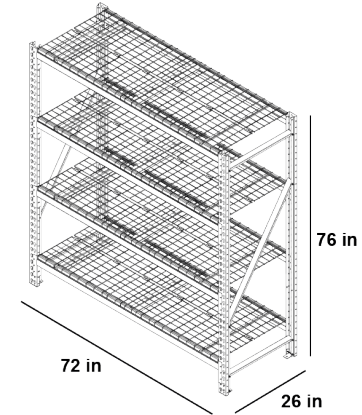

Key features

- 18-gauge steel structure.
- Adjustable height per level.
- Sturdy yet lightweight design.
- Easy assembly.
- Electrostatic powder coating.

Recommended uses

Workshops, warehouses, factories, offices, educational centers, and exhibitions.



Available colors



Load capacity
per level



Total load
capacity

4-LEVEL MASTER MODULAR RACK

STORE YOUR
FUTURE

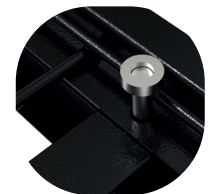
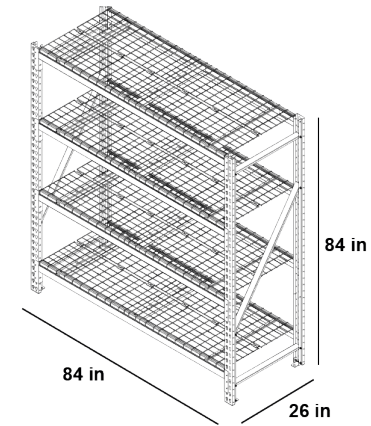

Key features

- 18-gauge steel structure.
- Adjustable height per level.
- Sturdy yet lightweight design.
- Easy assembly.
- Electrostatic powder coating.

Recommended uses

Workshops, warehouses, factories, offices, educational centers, and exhibitions.



Available colors



Load capacity
per level



Total load
capacity



OVERHEAD RACK

STORE YOUR
FUTURE

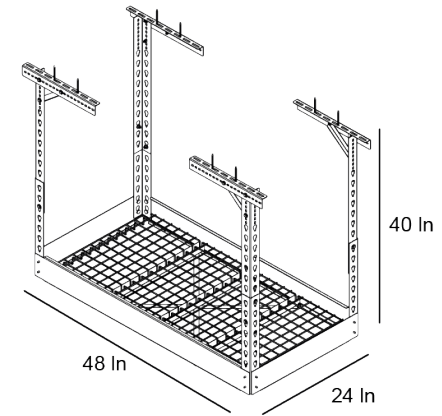

Available colors



Total load capacity

Key features

- 14-gauge steel structure.
- Ceiling-mounted installation.
- Adjustable shelves.
- Mesh-supported base.
- Electrostatic powder coating.

Recommended uses

Workshops, warehouses, factories, offices, educational centers, and exhibitions.

5-LEVEL MODULAR SHELF

STORE YOUR
FUTURE

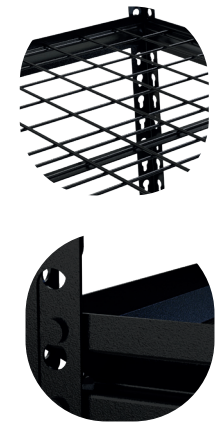
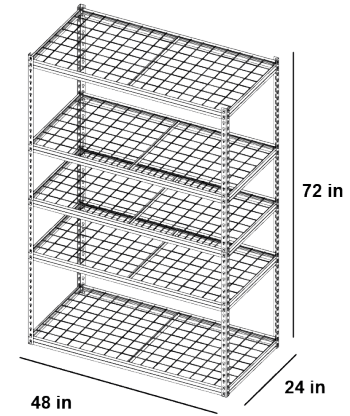

Available colors



Load capacity
per level



Total load
capacity

Key features

- 18-gauge steel structure.
- Adjustable height per level.
- Modular design.
- Easy assembly.
- Electrostatic powder coating.

Recommended uses

Workshops, warehouses, factories, offices, educational centers, and exhibitions.



Organize your
workspace in one place.

LOCKERS

2-DOOR LOCKER

STORE YOUR
FUTURE

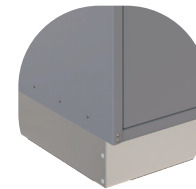
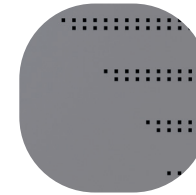
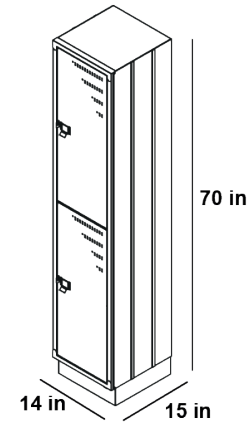

Available colors



Load capacity
per level



Total load
capacity

Key features

- 20-gauge steel structure.
- Padlock hasp system with label for individual control.
- Stainless steel base.
- Electrostatic powder coating.

Recommended uses

Workshops, warehouses, factories, offices, educational centers, and gyms.

4-DOOR LOCKER

STORE YOUR
FUTURE

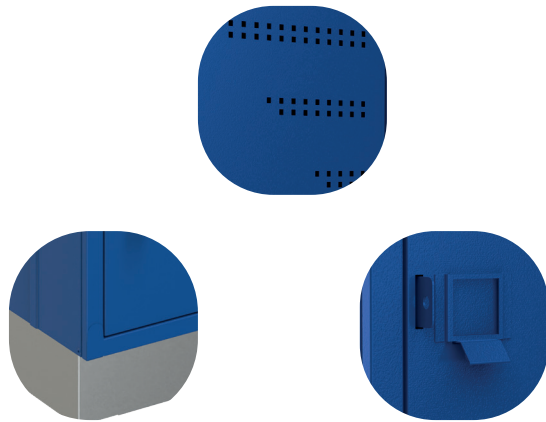
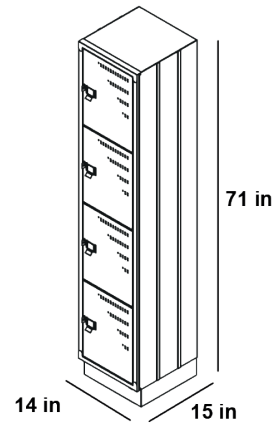

Key features

- 20-gauge steel structure.
- Padlock hasp system with label for individual control.
- Stainless steel base.
- Electrostatic powder coating.

Recommended uses

Workshops, warehouses, factories, offices, educational centers, and gyms.



Load capacity
per level



Total load
capacity



Available colors

6-DOOR LOCKER

STORE YOUR
FUTURE

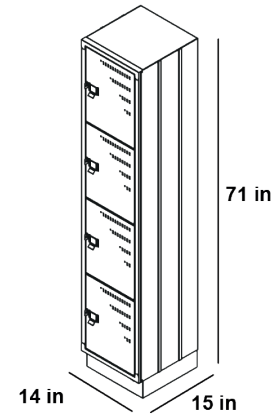

Available colors



Load capacity
per level



Total load
capacity

Key features

- 20-gauge steel structure.
- Padlock hasp system with label for individual control.
- Stainless steel base.
- Electrostatic powder coating.

Recommended uses

Workshops, warehouses, factories, offices, educational centers, and gyms.



**Functionality,
resistance and efficiency**
in a single system.

**WORKSHOP
FURNITURE**

INDUSTRIAL WORK TABLE

STORE YOUR
FUTURE

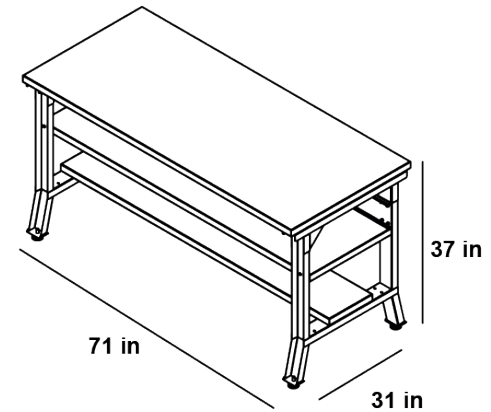

Available colors



Surface load capacity



Total load capacity

Key features

- Made of 16-gauge steel.
- Reinforced bases for greater stability.
- Reinforced top surface.
- Electrostatic powder coating.

Recommended uses

Garages, workshops, warehouses, industry, offices, schools, and laboratories.

ORGANIZER BOARD FOR INDUSTRIAL WORK TABLE

STORE YOUR
FUTURE

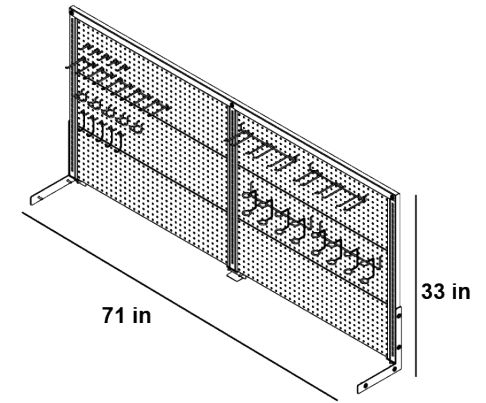
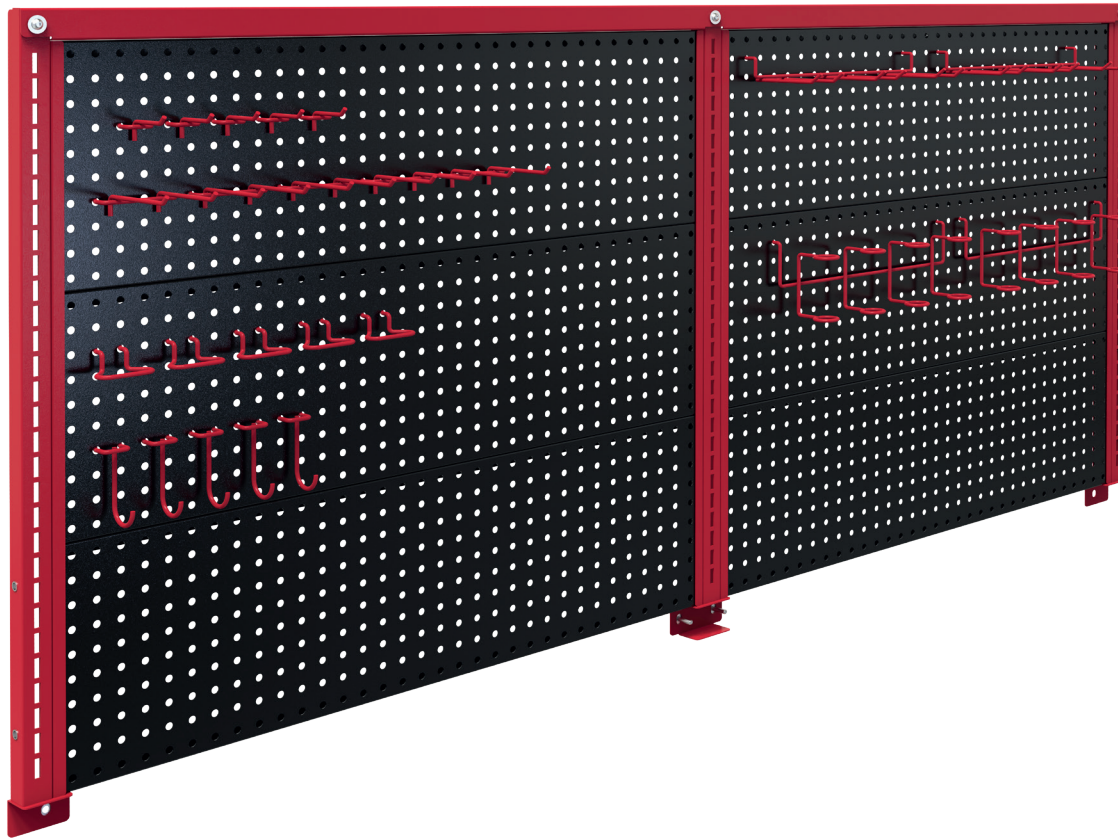

Includes kit with 20
organizer hooks.

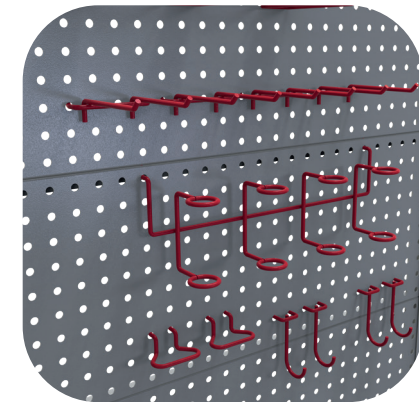

Key features

- Perforated panel made of 14-gauge steel for rigid tool support.
- Slotted frame made of 16-gauge steel.
- Electrostatic powder coating.



Available colors

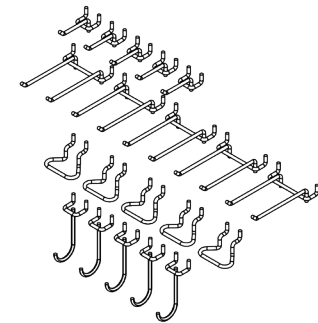

WORK TABLE DRAWER

STORE YOUR
FUTURE

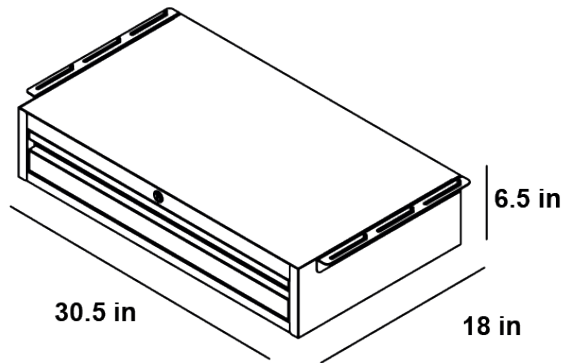

Key features

- Body made of 24-gauge steel.
- Equipped with aluminum trim for durability and a premium finish.
- Integrated front lock system.
- Compact design with hardware for under-surface mounting.
- Electrostatic powder coating.



Available colors

INDUSTRIAL WORK TABLE WITH ORGANIZER BOARD AND DRAWER

STORE YOUR
FUTURE

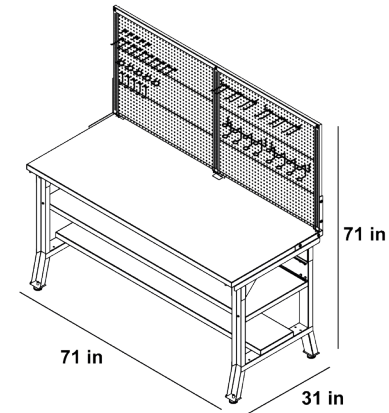

Available colors



Surface load
capacity



Total load
capacity

Key features

- Made of 16-gauge steel.
- Reinforced top bases.
- Organizer board with hooks.
- Industrial storage drawer.
- Electrostatic powder coating.

Recommended uses

Garages, workshops, warehouses, industry, offices, schools, and laboratories.

UTILITY CART

STORE YOUR
FUTURE

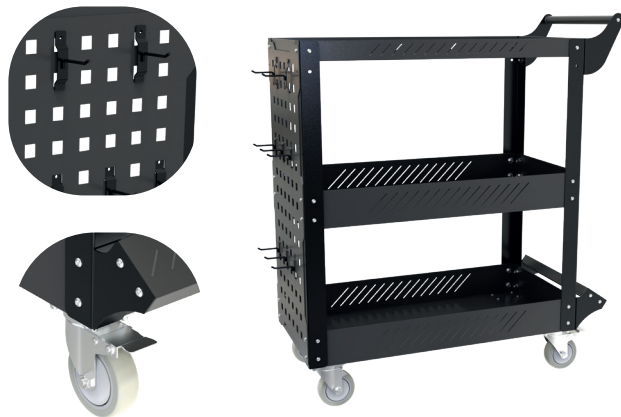
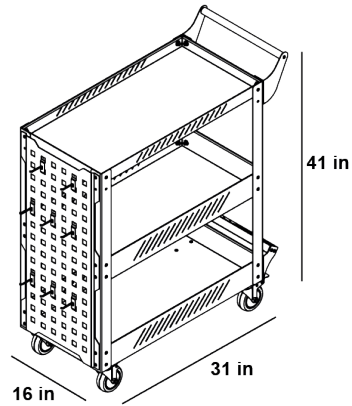

Key features

- Made of 18-gauge steel.
- Perforated panel with 8 hooks.
- Handle and footrest.
- Swivel casters with brake.
- Electrostatic powder coating.

Recommended uses

Garages, detailing studios, workshops, warehouses, industry, offices, schools, laboratories, and assembly areas.



Available colors



Load capacity
per level



Total load
capacity

UTILITY CART WITH DRAWER

STORE YOUR
FUTURE

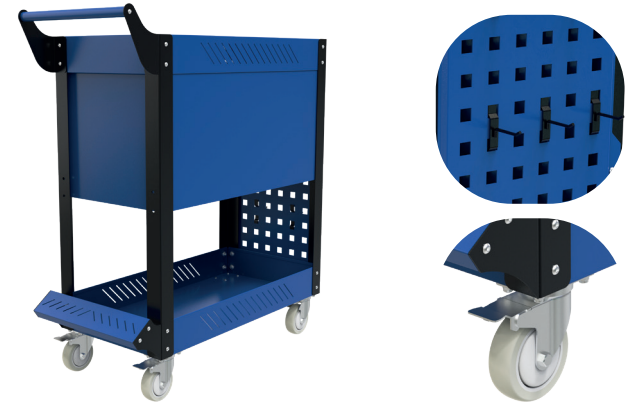
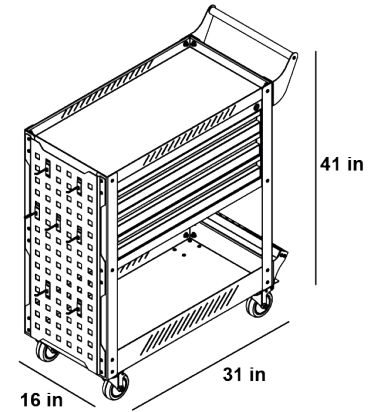

Available colors



Load capacity per drawer



Total load capacity

Key features

- Made of 18-gauge steel.
- Perforated panel with 8 hooks.
- Handle and footrest.
- Swivel casters with brake.
- 3 storage drawers.
- Electrostatic powder coating.

Recommended uses

Garages, detailing studios, workshops, warehouses, industry, offices, schools, laboratories, and assembly areas.

JOBSITE BOX

STORE YOUR
FUTURE

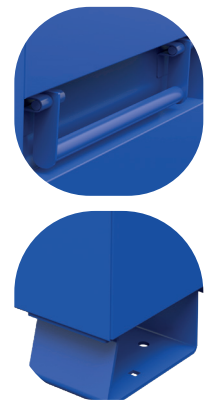
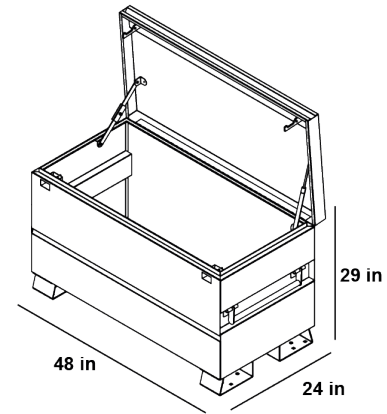

Available colors



Total load capacity

Key features

- One-piece body made of 16 and 18-gauge steel.
- Anchor system with 3/16" safety plate.
- Assisted opening with high-pressure gas struts.

Recommended uses

Workshops, warehouses, detailing studios, factories, storage facilities, and construction sites.

MOBILE WORKSTATION

STORE YOUR
FUTURE

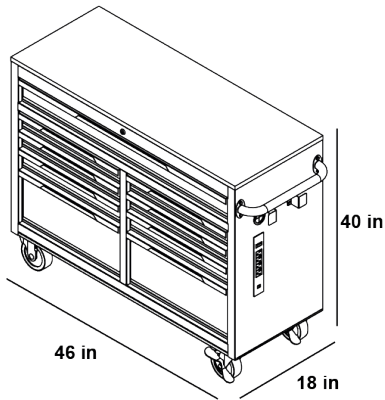

Key features

- Body made of 24-gauge steel.
- 9-drawer system.
- MDF top with pine wood veneer.
- Includes handle and high-mobility casters.
- Power strip with USB ports.

Recommended uses

Garages, detailing studios, workshops, warehouses, industry, assembly areas, and storage facilities.



Available colors



Load capacity
per drawer



Total load
capacity

Security solutions

so that your business can
operate without risks or worries.

Safe Box



BOLD SAFE

STORE YOUR
FUTURE

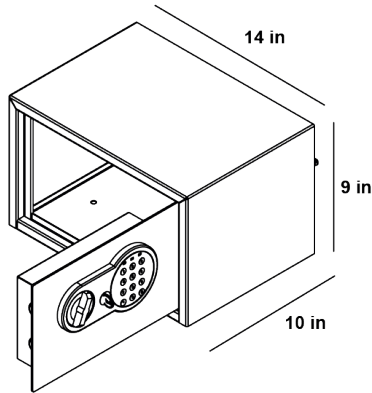

Key features

- Made of 18-gauge steel.
- Digital keypad lock.
- Mounting kit included.
- Concealed hinges.
- Power supply: 4 AA batteries.
- Electrostatic powder coating.

Recommended uses

Garages, workshops, warehouses, industry, storage facilities, and schools.



Available colors

MASTER SAFE

STORE YOUR
FUTURE

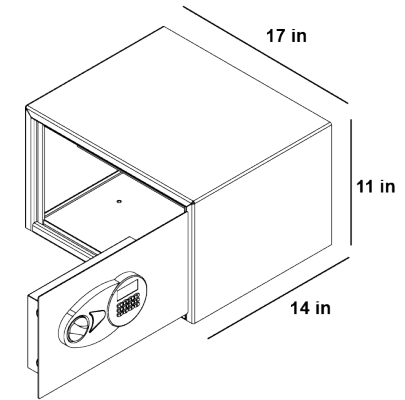

Available colors

Key features

- Made of 18-gauge steel.
- Digital keypad lock.
- Mounting kit included.
- Concealed hinges.
- Power supply: 4 AA batteries.
- Electrostatic powder coating.

Recommended uses

Garages, workshops, warehouses, industry, storage facilities, and schools.



Strategic display
that boosts your sales.

RETAIL SHELVING

PERIMETER RETAIL SHELVING

STORE YOUR
FUTURE

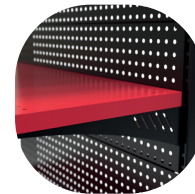
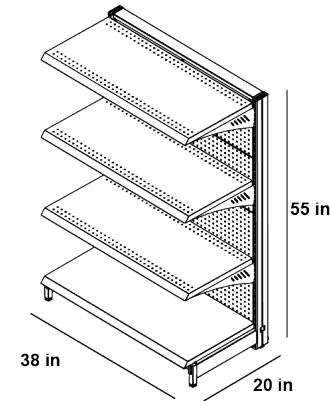

Available colors



Load capacity per level



Total load capacity

Key features

- Made of 22- and 14-gauge steel.
- Stable and secure structure even under heavy loads.
- Easy to assemble and integrate with other perimeter or center gondolas.
- Electrostatic powder coating.

Recommended uses

Retail stores, auto parts stores, showrooms, workshops, and points of sale.

CENTRAL RETAIL SHELVING

STORE YOUR
FUTURE

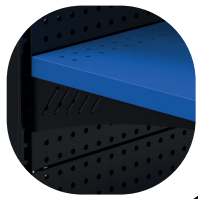
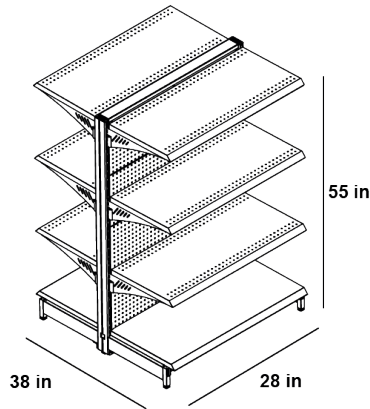

Key features

- Made of 22- and 14-gauge steel.
- Stable and secure structure even under heavy loads.
- Easy to assemble and integrate with other perimeter or center gondolas.
- Electrostatic powder coating.

Recommended uses

Retail stores, auto parts stores, showrooms, workshops, and points of sale.



Available colors



Load capacity
per level



Total load
capacity

RETAIL SHELVING SYSTEM

STORE YOUR
FUTURE



Available colors

Key features

- Made of 22- and 14-gauge steel.
- Stable and secure structure even under heavy loads.
- Easy to assemble and integrate with other perimeter or center gondolas.
- Electrostatic powder coating.

Recommended uses

Retail stores, auto parts stores, showrooms, workshops, and points of sale.

STORE YOUR
FUTURE



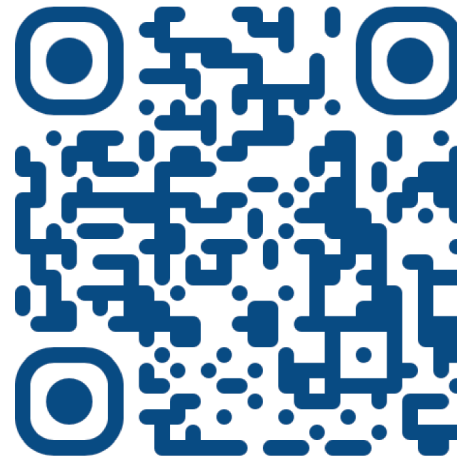

@starkguardmx



CONTACT US

11330 NW 36th Terrace, Doral,
Florida, 33178

hello@starkguard.com

Tel: 728 176 1461 Ext. 118
Cel. +52 554 202 2656
+52 561 178 5324